

HELI

www.heliforklift.net

12-16t

CPCD120-160

G series Internal Combustion Counterbalanced Forklift Truck



A. Enduring and durable

- Durable structure design
- Easy and high efficient daily inspection
- Improved protection performance
- Improved cooling efficiency

B. ENERGY-SAVING

- High efficient matching, forceful power
- Hydraulic dynamic load variable control system
- Intelligent sensitive thermal management system
- Light type design

C. COMFORTABLE AND CONVENIENT

- Easy get on-off
- Smaller turning radius
- Mast lower buffering
- Superior view
- More comfort driving experience

D. SAFE AND EFFICIENT

- Better reliability
- OPS (optional)
- Wet type drive axle
- High efficient working

G SERIES 12-16t

Technical parameters											
Model		CPCD120-C2Z-09	CPCD135-C2Z-06	CPCD150-C2Z-06	CPCD160-C2Z-06	CPCD140-C2Z-09	CPCD150-C2Z-09	CPCD160-C2Z-09	CPCD140-C2Z-12	CPCD150-C2Z-12	CPCD160-C2Z-12
Rated load	t	12	13.5	15	16	14	15	16	14	15	16
The mass	kg	17800	17800	18400	18800	20500	21000	21500	22500	23000	23500
Maximum lifting speed (loaded/unloaded)	mm/s	360/400	360/400	350/400	350/400	370/400	370/400	370/400	370/400	370/400	370/400
Maximum speed (loaded/unloaded)	km/h	25/27	25/27	26/28	26/28	26.2/27.3	26.2/27.3	26.2/27.3	26.2/27.3	26.2/27.3	26.2/27.3
Gradeability (loaded/unloaded)	%	36.4%/40%	36.4%/40%	36.4%/40%	36.4%/40%	36.4%/40%	36.4%/40%	36.4%/40%	36.4%/40%	36.4%/40%	36.4%/40%
Noise in the cab	dB(A)	≤73.8	≤73.8	≤73.8	≤73.8	≤73.8	≤73.8	≤73.8	≤73.8	≤73.8	≤73.8
Size parameters											
Overall length	mm	6705	6255	6265	6265	7105	7105	7105	7975	7975	7975
Overall width	mm	2560	2560	2560	2560	2560	2560	2560	2560	2560	2560
Overall height	mm	3365	3365	3380	3380	3340	3340	3340	3340	3340	3340
Load center distance	mm	900	600	600	600	900	900	900	1200	1200	1200
Wheelbase	mm	3250	3250	3250	3250	3500	3500	3500	3750	3750	3750
Front overhang	mm	785	785	795	795	935	935	935	935	935	935
Rear overhang	mm	850	850	850	850	850	850	850	850	850	850
Minimum underground clearance	mm	260	260	250	250	275	275	275	275	275	275
Seat height	mm	1970	1970	1985	1985	1985	1985	1985	1985	1985	1985
Turning radius (inside)	mm	220	220	220	220	220	220	220	220	220	220
Turning radius(outside)	mm	4450	4450	4500	4500	4750	4750	4750	5100	5100	5100
Front track	mm	1888	1888	1888	1888	1895	1895	1895	1895	1895	1895
Rear track	mm	2120	2120	2120	2120	2120	2120	2120	2120	2120	2120
Mast height (retracted/extended)	mm	3365/4865	3365/4865	3380/4880	3380/4880	3340/4840	3340/4840	3340/4840	3340/4840	3340/4840	3340/4840
Mast lifting height	mm	3000	3000	3000	3000	3000	3000	3000	3000	3000	3000
Mast tilting angle (forward/backward)	deg	6/12	6/12	6/12	6/12	6/12	6/12	6/12	6/12	6/12	6/12
Fork dimension (length*width*thickness)	mm	1820x200x85	1370x200x85	1370x200x85	1370x200x85	1820x200x95	1820x200x95	1820x200x95	2440x200x100	2440x200x100	2440x200x100
Fork adjusting range	mm	500-2370	500-2370	500-2370	500-2370	610-2150	610-2150	610-2150	610-2150	610-2150	610-2150

Vehicle configuration											
Truck model		CPCD120-C2Z-09	CPCD135-C2Z-06	CPCD150-C2Z-06	CPCD160-C2Z-06	CPCD140-C2Z-09	CPCD150-C2Z-09	CPCD160-C2Z-09	CPCD140-C2Z-12	CPCD150-C2Z-12	CPCD160-C2Z-12
Engine	Brand	CUMMINS	CUMMINS	CUMMINS	CUMMINS	CUMMINS	CUMMINS	CUMMINS	CUMMINS	CUMMINS	CUMMINS
	Model	QSB6.7	QSB6.7	QSB6.7	QSB6.7	QSB6.7	QSB6.7	QSB6.7	QSB6.7	QSB6.7	QSB6.7
	Rated power (kw/rpm)	129/2200	129/2200	129/2200	129/2200	145/2300	149/2200	149/2200	149/2200	149/2200	149/2200
	Rated torque (nm/rpm)	881/1300	881/1300	881/1300	881/1300	800/1500	990/1300	990/1300	990/1300	990/1300	990/1300
	Emission standard	Stage V	Stage V	Stage V	Stage V	Stage V	Stage V	Stage V	Stage V	Stage V	Stage V
Transmission	Model	ZF131	ZF131	ZF131	ZF131	ZF171	ZF171	ZF171	ZF171	ZF171	ZF171
Drive axle	Model	Meritor drive axle				Kessler	Kessler	Kessler	Kessler	Kessler	Kessler
Tire	Size	11.00-20	11.00-20	12.00-20	12.00-20	12.00-20	12.00-20	12.00-20	12.00-20	12.00-20	12.00-20
Auxiliary configuration	Backward radar	○	○	○	○	●	●	●	●	●	●
	Backward image	○	○	○	○	●	●	●	●	●	●
	Weighting system	○	○	○	○	○	○	○	○	○	○
	Ops for the whole truck	○	○	○	○	○	○	○	○	○	○
	Ops for mast	○	○	○	○	○	○	○	○	○	○
Hydraulic system	Consistent rate system	●	●	●	●	/	/	/	/	/	/
	Variable system	/	/	/	/	●	●	●	●	●	●
Air conditioner	Air conditioner	●	●	●	●	●	●	●	●	●	●
	Cooler	○	○	○	○	/	/	/	/	/	/
Tyre	Pneumatic tyre	●	●	●	●	●	●	●	●	●	●
	Solid tyre	○	○	○	○	○	○	○	○	○	○
	Solid tyre (front), pneumatic tyre (rear)	○	○	○	○	○	○	○	○	○	○
	Pneumatic tyre (front), solid tyre (rear)	○	○	○	○	○	○	○	○	○	○
Cab	Tilting cab	●	●	●	●	●	●	●	●	●	●

13.5t-600 15t-600 16t-600 12t-900 14t-900 15t-900 16t-900 14t-1200 15t-1200 16t-1200

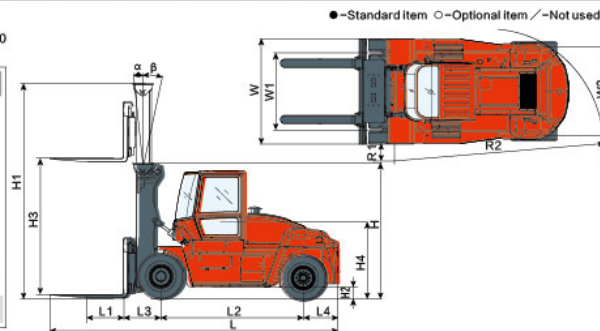
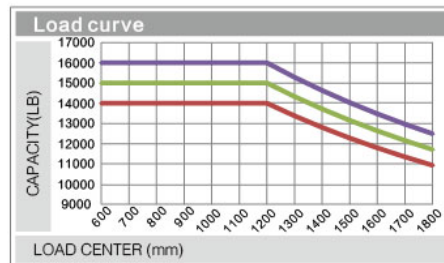
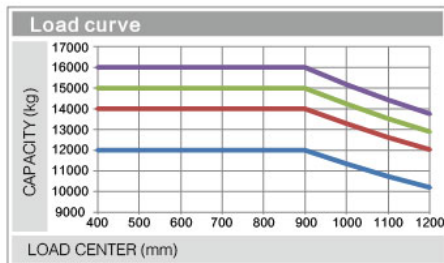
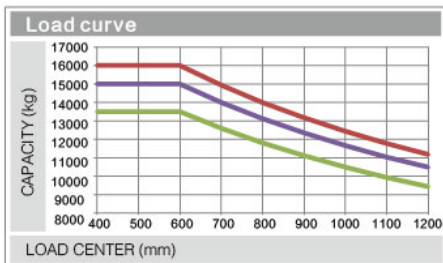

ANHUI HELI CO., LTD.
 Add / No.668, FangXing Road, Hefei, China
 Fax / +86-551-63639966

Tel / +86-551-63639068(America); 63639258(Europe);
 63639358(Asia); 636621105(Africa & Middle East);
 63639530(Key Accounts Division); 63662105(Wheel loader)

* Details of specifications and equipment are based on information available at time of printing and may change without notice.